



## Three-phase filters

FN 258	17
FN 351	20
FN 3025/FN 3026	23
FN 3100	26
FN 3120	29
FN 3258	32
FN 3270	35
FN 3359	38

**Three-phase filters.** EMC filter solutions for industrial applications like motor drives and machine tools. Furthermore, these types of filters are also suitable for mainframe computer systems, large uninterruptible power supplies, medical equipment, wind turbine power stations and a vast array of other three-phase power electronics.

Filter family	Max. voltage	Attenuation performance						Features										Typical applications									
		standard		high		very high		Multi-stage filter circuit	Safety connector blocks	Busbar connection	Optional protective covers	Standard protective covers	Offering EMC compliance	Low leakage current	DIN-rail mounting	Inverters, servo drives	Energy regeneration drives	Renewable energy generation	Machinery, machine tools	Industrial automation	Medical equipment	High power office equipment	General purpose				
FN 258 p. 17	480VAC 690VAC (HV)	7	250					■	■			■	■		■			■	■				■				
FN 351 p. 20	440VAC 520VAC (H)	8	280						■			■			■				■								
FN 3025 p. 23	520VAC	10 - 50							■			■	■	■	■				■	■	■	■					
FN 3026 p. 23	520VAC	10 - 50							■			■	■	■	■				■	■	■	■					
FN 3100 p. 26	520VAC	35	300						■			■			■	■	■	■	■								
FN 3120 p. 29	520VAC (H)	25	230						■			■			■	■	■	■	■								
FN 3258 p. 32	480VAC 520VAC (H)	7	180						■			■			■				■			■	■				
FN 3270 p. 35	520VAC (H)	10				1000			■	■	■	■			■				■	■			■				
FN 3359 p. 38	520VAC 690VAC (HV)	150				2500		■		■	■	■			■	■	■	■	■								

## 3-phase filters FN 258

### Book-style EMC/RFI filter for three-phase inverters and power drive systems

# SCHAFFNER

energy efficiency and reliability



- Industry standard EMC solution for three-phase PDS filtering
- Slim space-saving book-style housing
- Solid safety connector blocks or optional wire output connections
- Excellent attenuation performance
- HV versions for up to 690VAC
- HVIT versions for IT distribution networks
- P/L versions with low leakage current

#### Approvals



UL / CSA: FN 258 up to 180A (ex. -180-07)



UL / CSA: HV and HVIT up to 600VAC

#### Technical specifications

Maximum continuous operating voltage:	3x 480/277VAC (FN 258, FN 258L, FN 258P) 3x 690/400VAC (FN 258HV, FN 258HVIT)
Operating frequency:	dc to 60Hz
Rated currents:	7 to 250A @ 50° (480V filters) 7 to 130A @ 50° (690V filters)
High potential test voltage:	P → E 2650VDC for 2 sec (480V filters) P → P 2100VDC for 2 sec (480V filters) P → E 3100VDC for 2 sec (690V filters) P → P 3000VDC for 2 sec (690V filters)
Protection category:	IP20
Overload capability:	4x rated current at switch on, 1.5x rated current for 1 minute, once per hour
Temperature range (operation and storage):	-25°C to +100°C (25/100/21)
Flammability corresponding to:	UL 94V-2 or better
Design corresponding to:	UL 1283, CSA 22.2 No. 8 1986, IEC/EN 60939
MTBF @ 50°C/400V (Mil-HB-217F):	220,000 hours

#### Features and benefits

- FN 258 range of filters provides state-of-the-art EMI attenuation based on an innovative multi-stage filter topology. They help to ensure compliance with Class A or even Class B limits.
- The slim book-style shape allows a convenient and space-saving installation next to inverters and motor drives.
- With 480VAC rating and filter modules from 7 to 250A, FN 258 are ready for the most diverse applications worldwide.
- FN 258HV filters up to 130A are designed for 690VAC distribution networks.
- FN 258HVIT filters up to 150A meet the special requirements for the application in industrial 690VAC IT distribution networks.
- FN 258L and FN 258P filters help to fulfill tough requirements in respect of leakage current limitation and provide an excellent solution to overcome problems with nuisance tripping of sensitive earth leakage detectors.

#### Typical electrical schematic

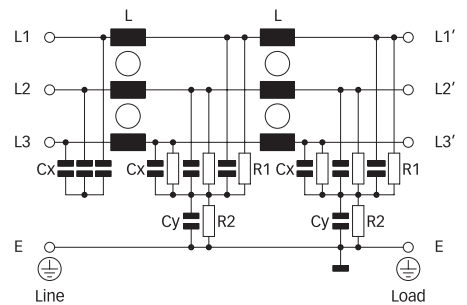

Note: HVIT versions without discharge resistor to ground.

#### Typical applications

- Three-phase variable speed drives and power drive systems (PDS)
- IT power distribution networks (FN 258HVIT)
- Applications comprising energy conversion devices (inverters, converters)
- Process automation equipment
- Three-phase power supplies and UPS
- Applications with low-leakage current requirements (FN 258L and FN 258P)

Filter selection table

Filter*	Rated current @ 50°C (40°C)	Typical drive power rating**	Leakage current*** @ 440VAC/50Hz	Power loss @ 25°C/50Hz	Input connections	Output connections	Weight
	[A]	[kW]	[mA]	[W]			[kg]
FN 258-7-..	7 (7.7)	4	16.5	9	-29	-07 -29	1.0
FN 258-16-..	16 (17.5)	7.5	18.3	20	-29	-07 -29	1.4
FN 258-30-..	30 (33)	15	24.2	21	-33	-07 -33	1.7
FN 258-42-..	42 (46)	22	25.8	30	-33	-07 -33	2.5
FN 258-55-..	55 (60)	30	25.8	30	-34	-07 -34	2.9
FN 258-75-34	75 (82)	37	25.8	24	-34	-34	3.9
FN 258-100-35	100 (110)	55	25.8	51	-35	-35	5.5
FN 258-130-35	130 (143)	75	30.0	50	-35	-35	6.9
FN 258-180-..	180 (197)	90	30.0	73	-40	-07 -40	11.0
FN 258-250-..	250 (275)	132	30.0	79	-40	-07 -40	12.0
FN 258HV-7-29	7 (7.7)	5.5	13.0	9	-29	-29	1.0
FN 258HV-16-29	16 (17.5)	11	19.0	20	-29	-29	1.5
FN 258HV-30-33	30 (33)	22	19.0	21	-33	-33	1.8
FN 258HV-42-33	42 (46)	30	21.6	30	-33	-33	2.6
FN 258HV-55-34	55 (60)	45	21.6	30	-34	-34	3.0
FN 258HV-75-34	75 (82)	55	21.6	24	-34	-34	4.3
FN 258HV-100-35	100 (110)	90	21.6	51	-35	-35	5.6
FN 258HV-130-35	130 (143)	110	25.0	50	-35	-35	7.1
FN 258HVIT-7-29	7 (7.7)	5.5	13.0	9	-29	-29	1.0
FN 258HVIT-16-29	16 (17.5)	11	19.0	20	-29	-29	1.5
FN 258HVIT-30-33	30 (33)	22	19.0	21	-33	-33	1.8
FN 258HVIT-42-33	42 (46)	30	21.6	30	-33	-33	2.6
FN 258HVIT-55-34	55 (60)	45	21.6	30	-34	-34	3.0
FN 258HVIT-75-34	75 (82)	55	21.6	24	-34	-34	4.3
FN 258HVIT-100-35	100 (110)	90	21.6	51	-35	-35	5.6
FN 258HVIT-130-35	130 (143)	110	25.0	50	-35	-35	7.1
FN 258L-7-..	7 (7.7)	4	0.8	9	-29	-07 -29	1.0
FN 258L-16-..	16 (17.5)	7.5	0.8	20	-29	-07 -29	1.4
FN 258L-30-..	30 (33)	15	0.8	21	-33	-07 -33	1.7
FN 258L-42-..	42 (46)	22	0.7	30	-33	-07 -33	2.5
FN 258L-55-..	55 (60)	30	0.7	30	-34	-07 -34	2.9
FN 258L-75-34	75 (82)	37	0.7	24	-34	-34	3.9
FN 258L-100-35	100 (110)	55	0.7	51	-35	-35	5.5
FN 258L-130-35	130 (143)	75	0.7	50	-35	-35	6.9
FN 258L-180-..	180 (197)	90	0.7	73	-40	-07 -40	11.0
FN 258L-250-07	250 (275)	132	0.7	79	-40	-07	12.0
FN 258P-7-..	7 (7.7)	4	3.3	9	-29	-07 -29	1.0
FN 258P-16-..	16 (17.5)	7.5	3.3	20	-29	-07 -29	1.4
FN 258P-30-..	30 (33)	15	3.3	21	-33	-07 -33	1.7
FN 258P-42-..	42 (46)	22	3.5	30	-33	-07 -33	2.5
FN 258P-55-..	55 (60)	30	3.5	30	-34	-07 -34	2.9
FN 258P-75-34	75 (82)	37	3.5	24	-34	-34	3.9
FN 258P-100-35	100 (110)	55	3.5	51	-35	-35	5.5
FN 258P-130-35	130 (143)	75	3.5	50	-35	-35	6.9
FN 258P-180-..	180 (197)	90	3.5	73	-40	-07 -40	11.0
FN 258P-250-07	250 (275)	132	3.6	79	-40	-07	12.0

\* To compile a complete part number, please replace the .. with the required output connection style.

\*\* Calculated at rated current, 440VAC (FN 258) / 690VAC (FN 258HV) and cos phi = 0.8. The exact value depends upon the efficiency of the drive, the motor and the entire application.

\*\*\* Maximum leakage under normal operating conditions (FN 258 at 440V, FN 258HV at 690V). Note: if two phases are interrupted, worst case leakage could reach 5.7 times higher levels.

Typical filter attenuation

Per CISPR 17; A = 50Ω/50Ω sym; B = 50Ω/50Ω asym; C = 0.1Ω/100Ω sym; D = 100Ω/0.1Ω sym

7 to 30A types

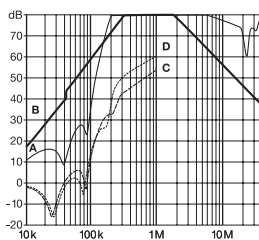

42 to 100A types

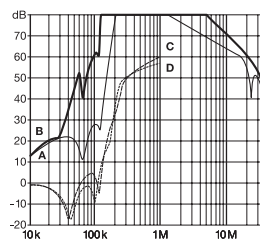

130A types

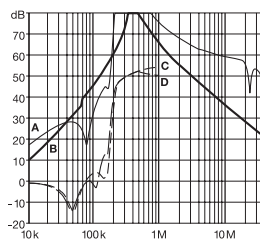

180 and 250A types

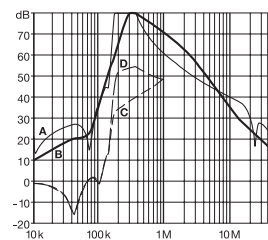

Note: typical attenuation performance of FN 258 standard filters. The behavior of FN 258HV, FN 258HVIT, FN 258P and FN 258L may be slightly different.

**Mechanical data**

7 to 55A types (-07)

7 to 130A types (-29, -33, -34, -35)

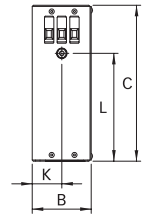
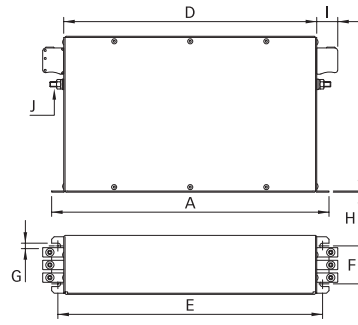
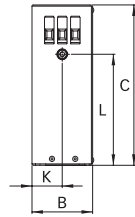
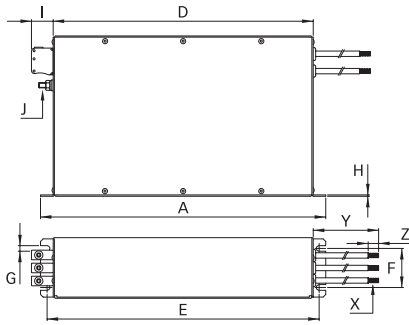

180 and 250A types (-07)

180 and 250A types (-40)

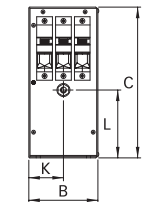
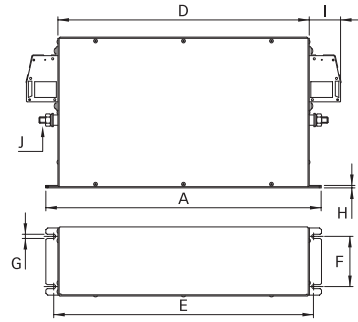
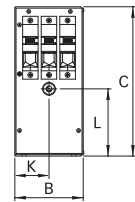
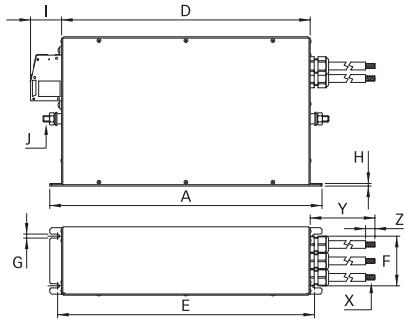

Note: in favour of a better readability, connectors and earth studs are not shown in the horizontal projection.

**Dimensions**

	7A	16A	30A	42A	55A	75A	100A	130A	180A	250A
<b>A</b>	255	305	335	329	329	329	379	439	438	478
<b>B</b>	50	55	60	70	80	80	90	110	110	110
<b>C</b>	126	142	150	185	185	220	220	240	240	240
<b>D</b>	225	275	305	300	300	300	350	400	400	440
<b>E</b>	240	290	320	314	314	314	364	414	413	453
<b>F</b>	25	30	35	45	55	55	65	80	80	80
<b>G</b>	6.5	6.5	6.5	6.5	6.5	6.5	6.5	6.5	6.5	6.5
<b>H</b>	1	1	1	1.5	1.5	1.5	1.5	3	4	4
<b>I</b>	10.9	10.9	25	25	39	39	45	45	49.5	49.5
<b>J</b>	M5	M5	M5	M6	M6	M6	M10	M10	M10	M10
<b>K</b>	25	27.5	30	35	40	40	45	55	55	55
<b>L</b>	85	100	110	130	105	140	130	140	110	110
<b>X*</b>	AWG 16	AWG 14	AWG 10	AWG 8	AWG 6				50mm <sup>2</sup>	70mm <sup>2</sup>
<b>Y*</b>	300 ±10	300 ±10	400 ±10	500 ±10	500 ±10				500 ±10	500 ±10
<b>Z*</b>	9	9	9	12	12				15	15

\* Filters with output wire connections (-07) only.

All dimensions in mm; 1 inch = 25.4mm

Tolerances according: ISO 2768 / EN 22768

**Filter input/output connector cross sections**

	-29	-33	-34	-35	-40
<b>Solid wire</b>	6mm <sup>2</sup>	16mm <sup>2</sup>	35mm <sup>2</sup>	50mm <sup>2</sup>	95mm <sup>2</sup>
<b>Flex wire</b>	4mm <sup>2</sup>	10mm <sup>2</sup>	25mm <sup>2</sup>	50mm <sup>2</sup>	95mm <sup>2</sup>
<b>AWG type wire</b>	AWG 10	AWG 6	AWG 2	AWG 1/0	AWG 4/0
<b>Recommended torque</b>	0.6 - 0.8Nm	1.5 - 1.8Nm	4.0 - 4.5Nm	7 - 8Nm	17 - 20Nm

Please visit [www.schaffner.com](http://www.schaffner.com) to find more details on filter connectors.

## 3-phase filters FN 351

### General purpose EMC filter for three-phase applications

# SCHAFFNER

energy efficiency and reliability



- EMC solution for industrial inverters and motor drives
- Rated currents from 8 to 280A
- Selectable voltage level of 440V and 520V
- High differential and common-mode attenuation
- Compliant with IEC 60950

#### Approvals



#### Technical specifications

Maximum continuous operating voltage:	3x 440/250VAC (FN 351) 3x 520/300VAC (FN 351H)
Operating frequency:	dc to 60Hz
Rated currents:	8 to 280A @ 40°C
High potential test voltage:	P → E 2600VDC for 2 sec (FN 351) P → P 1900VDC for 2 sec (FN 351) P → E 2750VDC for 2 sec (FN 351H) P → P 2250VDC for 2 sec (FN 351H)
Protection category:	IP20
Overload capability:	4x rated current at switch on, 1.5x rated current for 1 minute, once per hour
Temperature range (operation and storage):	-25°C to +85°C (25/085/21) (FN 351) -25°C to +100°C (25/100/21) (FN 351H)
Flammability corresponding to:	UL 94V-2 or better
Design corresponding to:	UL 1283, CSA 22.2 No. 8 1986, IEC/EN 60939
MTBF @ 40°C/400V (Mil-HB-217F):	135,000 hours

#### Typical electrical schematic

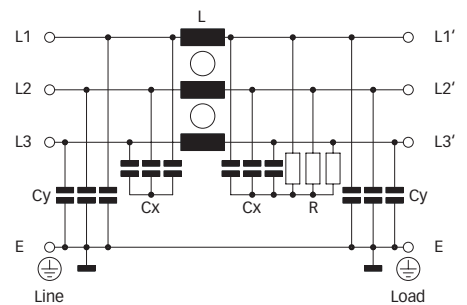



#### Features and benefits

- Broad range of power ratings for fast and convenient filter selection.
- Available as 440VAC (FN 351) and 520VAC (FN 351H) versions for network-specific applications.
- FN 351 filters provide a broadband common and differential-mode attenuation performance, which remains available also when high interference levels are present.
- Solid, touch-safe filter terminals contribute to overall equipment safety and make the filters compliant with IEC 60950.
- Introduced as one of the very first motor drive EMC filters in the market, FN 351 has been widely imitated and has successfully proven its function over more than 10 years.

#### Typical applications

- Three-phase motor drives
- Inverters and converters
- Industrial automation equipment
- UPS
- SMPS
- General purpose three-phase filtering

Filter selection table

Filter*	Rated current @ 40°C (25°C)	Typical drive power rating**	Leakage current*** @ 400VAC/50Hz	Power loss @ 25°C/50Hz	Input/Output connections		Weight
	[A]	[kW]	[mA]	[W]			[kg]
FN 351-8-29	8 (9.2)	3	1.9	7	-29		0.8
FN 351-16-29	16 (18.5)	5.5	1.9	8	-29		1.3
FN 351-25-33	25 (28.9)	11	28.0	8	-33		1.4
FN 351-36-33	36 (41.6)	15	28.0	9	-33		1.5
FN 351-50-..	50 (57.7)	22	29.5	11	-33	-34	1.6
FN 351-64-..	64 (73.9)	30	29.5	15	-33	-34	1.7
FN 351-80-34	80 (92.3)	37	31.8	23	-34		5.6
FN 351-110-35	110 (127)	55	31.8	25	-35		5.8
FN 351-180-36	180 (208)	90	29.6	49	-36		13.0
FN 351-280-37	280 (323)	132	35.7	70	-37		28.0
FN 351H-8-29	8 (9.2)	4	2.3	7	-29		1.1
FN 351H-16-29	16 (18.5)	7.5	2.3	8	-29		1.3
FN 351H-25-33	25 (28.9)	15	32.7	8	-33		1.4
FN 351H-36-33	36 (41.6)	18.5	32.7	9	-33		1.5
FN 351H-50-..	50 (57.7)	30	32.7	11	-33	-34	1.6
FN 351H-64-33	64 (73.9)	37	32.7	15	-33		1.7
FN 351H-80-34	80 (92.3)	45	38.0	23	-34		5.6
FN 351H-110-35	110 (127)	75	38.0	25	-35		5.8
FN 351H-180-36	180 (208)	110	35.6	49	-36		13.0
FN 351H-280-37	280 (323)	160	42.9	70	-37		28.0

\* To compile a complete part number, please replace the .. with the required I/O connection style.  
 \*\* Calculated at rated current, 400VAC (FN 351)/480VAC (FN 351H) and cos phi = 0.8. The exact value depends upon the efficiency of the drive, the motor and the entire application.  
 \*\*\* Maximum leakage under normal operating conditions (FN 351 at 400V, FN 351H at 480V). Note: if two phases are interrupted, worst case leakage could reach 6 times higher levels.

Typical filter attenuation

Per CISPR 17; A = 50Ω/50Ω sym; B = 50Ω/50Ω asym; C = 0.1Ω/100Ω sym; D = 100Ω/0.1Ω sym

8A types

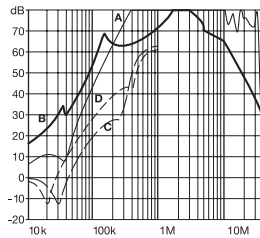

16A types

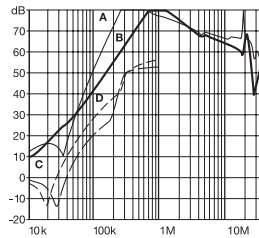

25A types

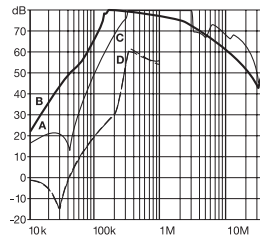

36 and 50A types

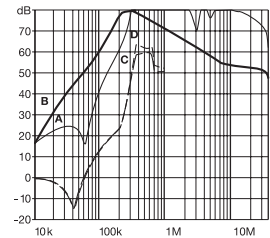

64A types

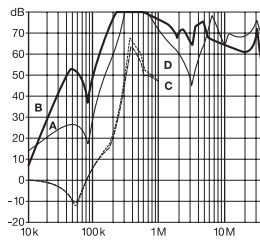

80 and 110A types

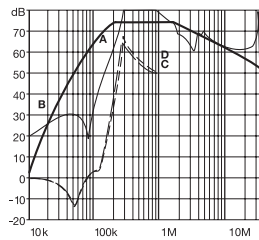

180A types

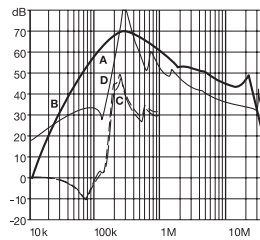

280A types

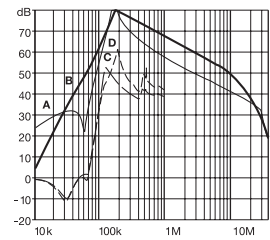

**Mechanical data**

8 and 16A types

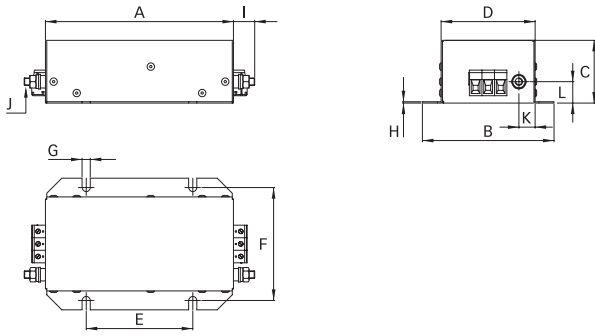

25 to 64A types

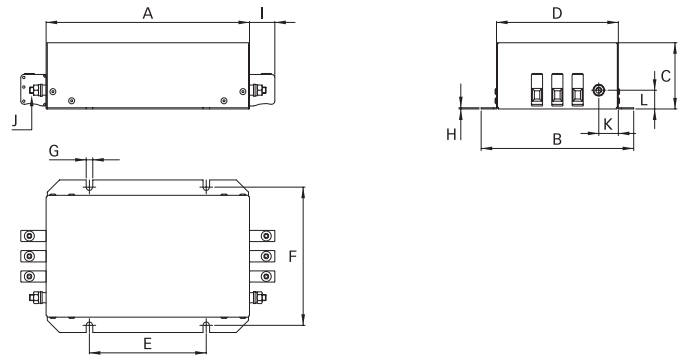

80 and 110A types

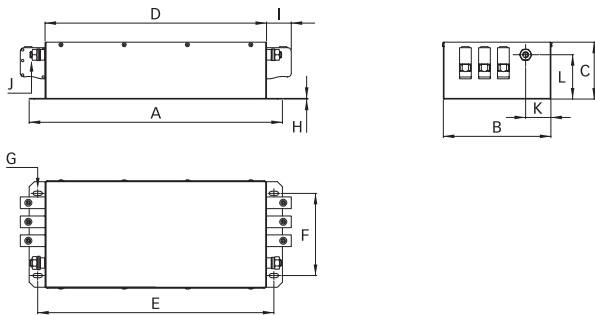

180 and 280A types

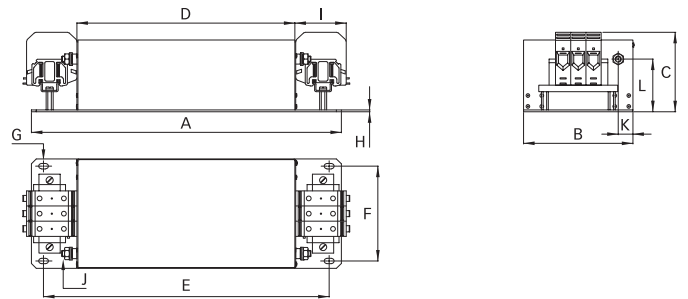

**Dimensions**

	8A	8A (-H)	16A	25A	36A	50A (-33)	50A (-34)	64A (-33)	64A (-34)	80A	110A	180A	280A
<b>A</b>	180	200	200	200	200	200	200	200	200	400	400	510	700
<b>B</b>	115	150	150	150	150	150	150	150	150	170	170	180	260
<b>C</b>	60	65	65	65	65	65	80	65	80	90	90	130	155
<b>D</b>	85	120	120	120	120	120	120	120	120	350	350	360	530
<b>E</b>	115	115	115	115	115	115	115	115	115	373	373	470	660
<b>F</b>	100	136	136	136	136	136	136	136	136	130	130	156	220
<b>G</b>	6.5	6.5	6.5	6.5	6.5	6.5	6.5	6.5	6.5	15 x 6.5	15 x 6.5	16 x 9	16 x 9
<b>H</b>	1	1	1	1	1	1	1	1	1	1	1	4	4
<b>I</b>	17	17	17	25	25	25	39	25	39	39	45	85	110
<b>J</b>	M6	M6	M6	M6	M6	M6	M6	M6	M6	M10	M10	M10	M10
<b>K</b>	13	19.25	19.25	19.25	19.25	19.25	18.75	19.25	18.75	40	40	25	30
<b>L</b>	17	17	17	18.4	18.4	18.4	17	18.4	17	70	70	85	100

All dimensions in mm; 1 inch = 25.4mm  
Tolerances according: ISO 2768 / EN 22768

**Filter input/output connector cross sections**

	-29	-33	-34	-35	-36	-37
<b>Solid wire</b>	6mm <sup>2</sup>	16mm <sup>2</sup>	35mm <sup>2</sup>	50mm <sup>2</sup>	95mm <sup>2</sup>	150mm <sup>2</sup>
<b>Flex wire</b>	4mm <sup>2</sup>	10mm <sup>2</sup>	25mm <sup>2</sup>	50mm <sup>2</sup>	95mm <sup>2</sup>	150mm <sup>2</sup>
<b>AWG type wire</b>	AWG 10	AWG 6	AWG 2	AWG 1/0	AWG 4/0	AWG 6/0
<b>Recommended torque</b>	0.6 - 0.8Nm	1.5 - 1.8Nm	4.0 - 4.5Nm	7 - 8Nm	17 - 20Nm	27 - 30Nm

Please visit [www.schaffner.com](http://www.schaffner.com) to find more details on filter connectors.

## 3-phase filters FN 3025 / FN 3026

### Advanced EMC/RFI filter concept with minimum leakage current

# SCHAFFNER

energy efficiency and reliability



- Compact state-of-the-art filter concept
- Light weight plastic enclosure design
- Minimized filter leakage current
- Hinged safety covers
- Revolutionary embedded filter terminals
- Chassis or DIN-rail mounting option
- Selectable performance level
- Environmental friendly design without potting compound

#### Approvals



(Approvals pending)



#### Technical specifications

Maximum continuous operating voltage:	3x 520/300VAC
Operating frequency:	dc to 60Hz
Rated currents:	10 to 50A @ 50°C
High potential test voltage:	P → E 2000VAC for 2 sec P → P 2250VDC for 2 sec
Protection category:	IP00 (protection according to VBG 4)
Overload capability:	4x rated current at switch on, 1.5x rated current for 1 minute, once per hour
Temperature range (operation and storage):	-25°C to +100°C (25/100/21)
Flammability corresponding to:	UL 94V-2 or better
Design corresponding to:	UL 1283, CSA 22.2 No. 8 1986, IEC/EN 60939
MTBF @ 50°C/400V (Mil-HB-217F):	>200,000 hours

#### Features and benefits

- FN 3025 filters are designed for traditional chassis mounting.
- For extra fast installation, FN 3026 filters can comfortably be snapped-in on TS 35 DIN-rails.
- Two different performance levels are offered (L types, P types). The suitable filter can be selected by choosing the required performance level, the admissible leakage current and the preferred installation style.
- A plastic housing and a metal ground plate are cleverly combined to get the lowest possible product weight without compromising EMC behavior.
- The embedded jump-terminal system from Schaffner guarantees user-friendly handling as well as fast and reliable electrical connection.
- Captive hinged protective covers contribute to overall safety by offering protection against unintended contact with live conductors. They are included in the standard delivery package without causing extra cost.
- Very low leakage current values make these filter ranges ideally suitable for use in Japanese electricity networks as well as in applications which set value on safety and reliability.

#### Typical electrical schematic

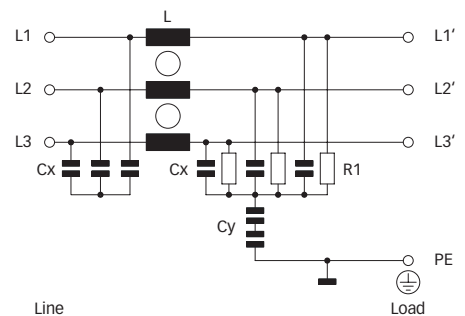

#### Typical applications

- Applications with the requirement for extremely compact filter solutions
- Applications with tough leakage current requirements or sensitive earth leakage detectors
- Applications with insufficient internal filtering or moderate interference levels
- Automation equipment
- Motor drives and servo drives with short motor cables
- Applications including stepping motors
- Semiconductor manufacturing equipment
- Electrical cabinets
- Three-phase power supplies
- Medical equipment (not patient-coupled)

**Filter selection table**

Filter	Rated current @ 50°C (40°C)	Typical drive power rating*	Leakage current** @ 480VAC/50Hz	Power loss @ 25°C/50Hz	Input/Output connections 	Weight
	[A]	[kW]	[mA]	[W]		[kg]
FN 3025HL-10-71	10 (10.7)	5.5	0.4	4.8	-71	0.52
FN 3025HL-20-71	20 (21.4)	11	0.4	6.2	-71	0.52
FN 3025HL-30-71	30 (32.1)	18.5	0.4	7.0	-71	0.54
FN 3025HL-50-72	50 (53.5)	30	0.4	10.5	-72	0.93
FN 3025HP-10-71	10 (10.7)	5.5	2.5	4.8	-71	0.52
FN 3025HP-20-71	20 (21.4)	11	2.5	6.2	-71	0.52
FN 3025HP-30-71	30 (32.1)	18.5	2.5	7.0	-71	0.54
FN 3025HP-50-72	50 (53.5)	30	2.5	10.5	-72	0.93
FN 3026HL-10-71	10 (10.7)	5.5	0.4	4.8	-71	0.56
FN 3026HL-20-71	20 (21.4)	11	0.4	6.2	-71	0.56
FN 3026HL-30-71	30 (32.1)	18.5	0.4	7.0	-71	0.58
FN 3026HL-50-72	50 (53.5)	30	0.4	10.5	-72	0.98
FN 3026HP-10-71	10 (10.7)	5.5	2.5	4.8	-71	0.56
FN 3026HP-20-71	20 (21.4)	11	2.5	6.2	-71	0.56
FN 3026HP-30-71	30 (32.1)	18.5	2.5	7.0	-71	0.58
FN 3026HP-50-72	50 (53.5)	30	2.5	10.5	-72	0.98

\* Calculated at rated current, 480VAC and cos phi = 0.8. The exact value depends upon the efficiency of the drive, the motor and the entire application.

\*\* Maximum leakage under normal operating conditions. Note: if two phases are interrupted, worst case leakage could reach up to 10 times higher levels (at 520VAC/60Hz).

**Typical filter attenuation**

Per CISPR 17; A = 50Ω/50Ω sym; B = 50Ω/50Ω asym; C = 0.1Ω/100Ω sym; D = 100Ω/0.1Ω sym

10 and 20A HL types

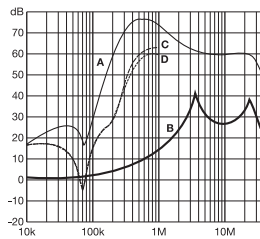

10 and 20A HP types

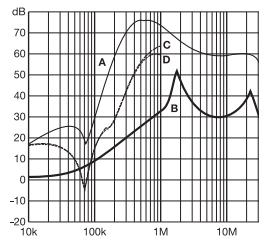

30 and 50A HL types

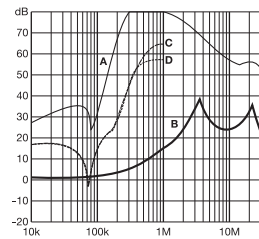

30 and 50A HP types

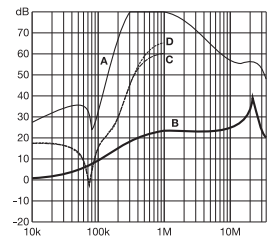

**Installation**

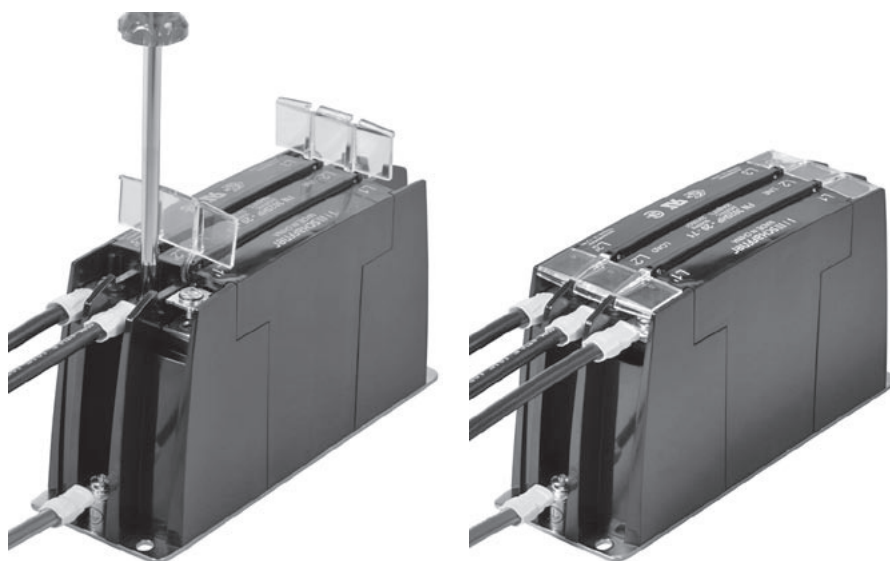

FN 3025/FN 3026 are delivered with closed plastic covers and unfastened terminals. To install the filter please proceed as follows:

- Mount the filter on a metal surface with four screws or snap it onto a TS 55 DIN-rail.
- First connect the green/yellow wire to the earth stud of the filter.
- Gently lift the two hinged plastic covers.
- Connect phase wires with cable lugs by pushing down and tightening the screws.
- Please note the torque recommendation on top of the filter.
- Push the covers back into their locked position to finish the filter installation.

**Mechanical data**

FN 3025

FN 3026

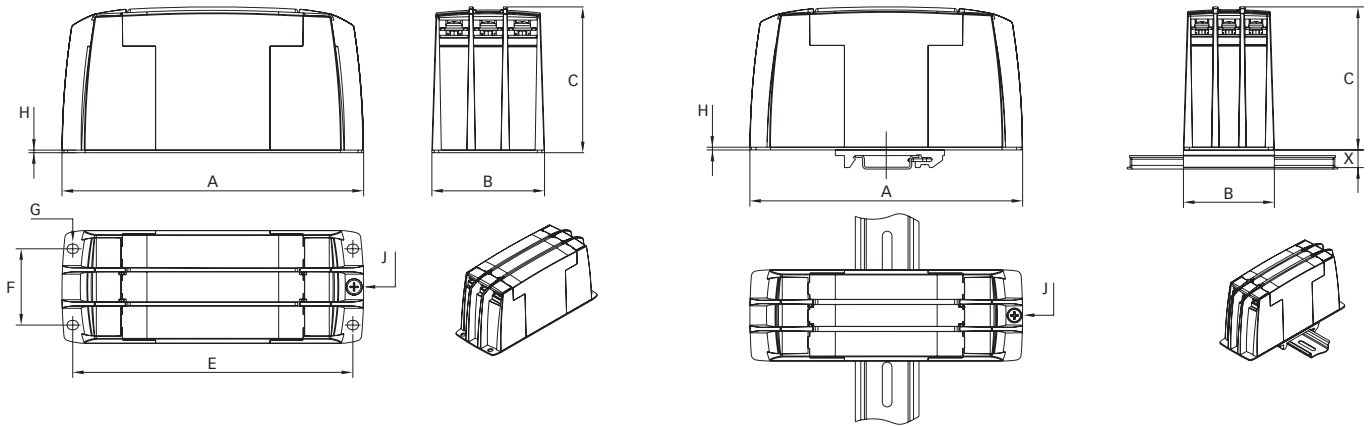

**Dimensions**

	FN 3025 10A	20A	30A	50A	FN 3026 10A	20A	30A	50A
<b>A</b>	150	150	150	177	150	150	150	177
<b>B</b>	50	50	50	65	50	50	50	65
<b>C</b>	78	78	78	84	78	78	78	84
<b>E</b>	140	140	140	162				
<b>F</b>	32	32	32	44				
<b>G</b>	4.3 x 5.5	4.3 x 5.5	4.3 x 5.5	5.3 x 6.5				
<b>H</b>	1.5	1.5	1.5	1.5	1.5	1.5	1.5	1.5
<b>J</b>	M4	M4	M4	M5	M4	M4	M4	M5
<b>X</b>					9.7	9.7	9.7	9.7

All dimensions in mm; 1 inch = 25.4mm  
Tolerances according: ISO 2768 / EN 22768

**Filter input/output connector cross sections**

	-71 (10A)	-71 (20A)	-71 (30A)	-72 (50A)
<b>Flex wire</b>	1.3 - 2.5mm <sup>2</sup>	4 - 6mm <sup>2</sup>	8 - 10mm <sup>2</sup>	16 - 20mm <sup>2</sup>
<b>AWG type wire</b>	AWG 16 - AWG 13	AWG 12 - AWG 10	AWG 8 - AWG 7	AWG 5 - AWG 4
<b>Ring/fork lug (W/d)*</b>	max. 11mm (9.5mm)/ min. Ø4.3mm**	max. 11mm (9.5mm)/ min. Ø4.3mm**	max. 11mm (9.5mm)/ min. Ø4.3mm**	max. 16.5mm (15mm)/ min. Ø5.3mm**
<b>Recommended torque</b>	1.0 - 1.2Nm	1.0 - 1.2Nm	1.0 - 1.2Nm	1.9 - 2.2Nm

\* Schaffner recommends the use of insulated and UL-recognized ring lugs or fork lugs of the appropriate size.

\*\* Specification in ( ) relates to earth connector.

Please visit [www.schaffner.com](http://www.schaffner.com) to find more details on filter connectors.

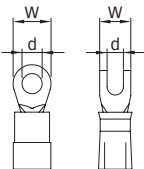

## 3-phase filters FN 3100

### EMC/RFI filter for regenerative motor drives

# SCHAFFNER

energy efficiency and reliability



- Exceptional broadband attenuation performance from 10kHz up to 30MHz
- Equally suitable for conventional and regenerative motor drives (latter with additional line reactor only)
- Slim and user-friendly book-style design with touch-safe terminal blocks for minimum space and maximum safety
- Enables compliance with Class B limits

#### Approvals



FN 3100 up to 150A



#### Technical specifications

Maximum continuous operating voltage:	3x 520/300VAC
Operating frequency:	dc to 60Hz
Rated currents:	35 to 300A @ 50°C
High potential test voltage:	P → E 2750VDC for 2 sec P → P 2250VDC for 2 sec
Protection category:	IP20
Overload capability:	4x rated current at switch on, 1.5x rated current for 1 minute, once per hour
Temperature range (operation and storage):	-25°C to +100°C (25/100/21)
Flammability corresponding to:	UL 94V-2 or better
Design corresponding to:	UL 1283, CSA 22.2 No. 8 1986, IEC/EN 60939
MTBF @ 50°C/400V (Mil-HB-217F):	>400,000 hours

#### Features and benefits

- High performance filter for mainly industrial motor drive applications with significant interference levels.
- Attenuation performance for Class B compliance in applications comprising multiple motor drives (e.g. machine tool with up to 8 driving axes with ~10 to 20m motor cable each).
- Broadband filter performance with low frequency attenuation down to 10kHz for reliable suppression of conducted interference in applications with regenerative motor drives.
- Slim book-style shape requiring minimum cabinet space and allowing convenient installation right beside the motor drive.
- Touch-safe terminal blocks provide unsurpassed electrical safety and contacting cross section according to EN 60204-1 installation standard.
- For even better filter specifications, please consider FN 3120H series from Schaffner.

#### Typical electrical schematic

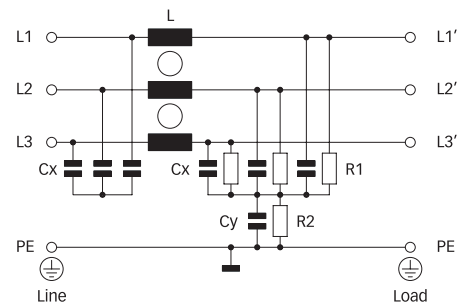

#### Typical applications

- Conventional motor drives with long motor cables and high interference levels
- Four quadrant motor drives and servo drives with energy regeneration mode (in combination with a suitable line reactor)
- Industrial applications comprising power conversion devices, such as machinery, machine tools and process automation equipment
- Uninterruptible power supplies (UPS)
- Converters for renewable energy generation
- Thyristor drives
- Elevators and cranes

**Filter selection table**

Filter	Rated current @ 50°C (40°C)	Typical drive power rating*	Leakage current** @ 400VAC/50Hz	Power loss @ 25°C/50Hz	Input/Output connections	Weight
	[A]	[kW]	[mA]	[W]		[kg]
FN 3100-35-33	35 (38.4)	22	48.9	11.8	-33	2.3
FN 3100-50-34	50 (54.8)	30	66.1	18.0	-34	3.4
FN 3100-80-35	80 (87.6)	45	71.5	25.9	-35	5.3
FN 3100-110-35	110 (120.5)	55	71.5	32.7	-35	5.4
FN 3100-150-40	150 (164.3)	75	71.5	50.6	-40	8.5
FN 3100-200-40	200 (219)	110	71.5	67.2	-40	9.1
FN 3100-230-40	230 (230)	132	71.5	36.5	-40	9.2
FN 3100-300-99	300 (329)	160	71.5	54.0	-99	11.8

\* Calculated at rated current, 480VAC and cos phi = 0.8. The exact value depends upon the efficiency of the drive, the motor and the entire application.  
 \*\* Maximum leakage under normal operating conditions. Note: if two phases are interrupted, worst case leakage could reach 5.3 times higher levels.

**Typical filter attenuation**

Per CISPR 17; A = 50Ω/50Ω sym; B = 50Ω/50Ω asym; C = 0.1Ω/100Ω sym; D = 100Ω/0.1Ω sym

35 to 80A types

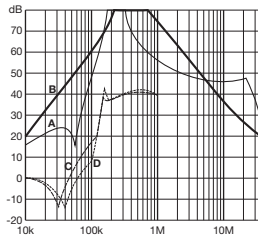

110 and 150A types

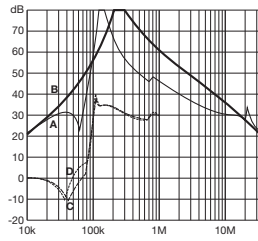

200A types

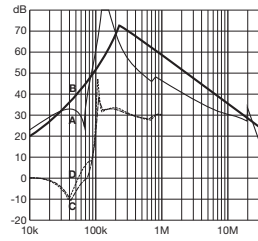

230 and 300A types

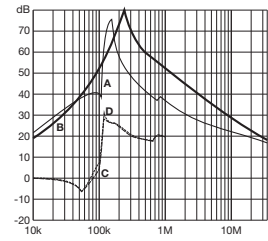

**Mechanical data**

35 to 230A types

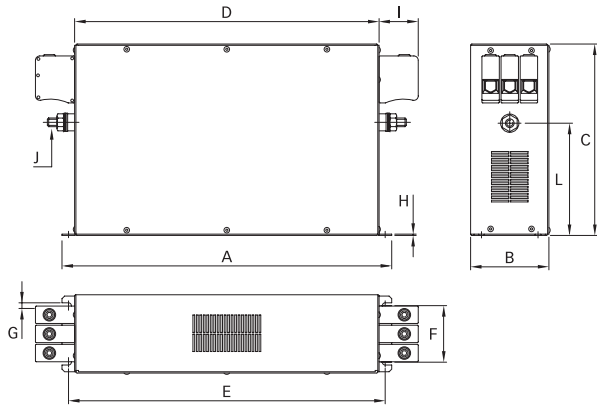

300A types

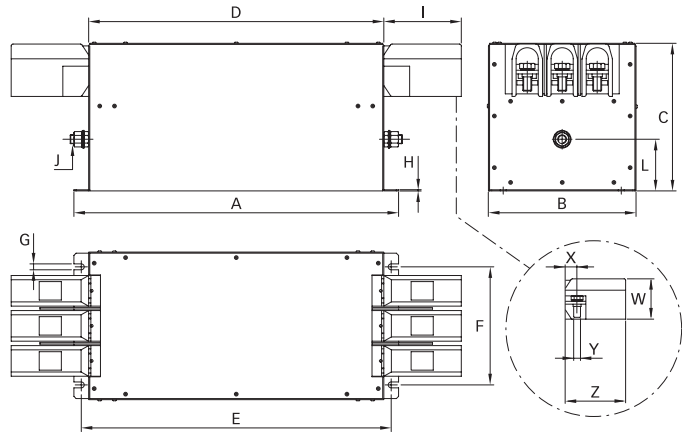

**Dimensions**

	35A	50A	80A	110A	150A	200A	230A	300A
<b>A</b>	335	329	379	379	438	438	438	440
<b>B</b>	60	80	90	90	110	110	110	200
<b>C</b>	150	185	220	220	240	240	240	200
<b>D</b>	305	300	350	350	400	400	400	400
<b>E</b>	320	314	364	364	413	413	413	420
<b>F</b>	35	55	65	65	80	80	80	160
<b>G</b>	6.5	6.5	6.5	6.5	6.5	6.5	6.5	8
<b>H</b>	1	1.5	1.5	1.5	4	4	4	1.5
<b>I</b>	25	39	45	45	50	50	50	105
<b>J</b>	M5	M6	M10	M10	M10	M10	M10	M12
<b>L</b>	93.5	107	129	129	108	108	108	70
<b>W</b>								71.5
<b>X</b>								~22
<b>Y</b>								M12
<b>Z</b>								~105

All dimensions in mm; 1 inch = 25.4mm  
Tolerances according: ISO 2768 / EN 22768

**Filter input/output connector cross sections**

	-33	-34	-35	-40	-99
<b>Solid wire</b>	16mm <sup>2</sup>	35mm <sup>2</sup>	50mm <sup>2</sup>	95mm <sup>2</sup>	-
<b>Flex wire</b>	10mm <sup>2</sup>	25mm <sup>2</sup>	50mm <sup>2</sup>	95mm <sup>2</sup>	150mm <sup>2</sup>
<b>AWG type wire</b>	AWG 6	AWG 2	AWG 1/0	AWG 4/0	AWG 6/0
<b>Recommended torque</b>	1.5 - 1.8Nm	4.0 - 4.5Nm	7 - 8Nm	17 - 20Nm	27 - 30Nm

Please visit [www.schaffner.com](http://www.schaffner.com) to find more details on filter connectors.

## High-end EMC/RFI filter for conventional and regenerative drives

# SCHAFFNER

energy efficiency and reliability



- High-performance filter for extremely noisy applications
- Ideal for the latest regenerative drives (with additional line impedance)
- Significantly improves the reliability and immunity of installations
- Enables compliance with Class B limits even with very long cables

### Approvals



### Technical specifications

Maximum continuous operating voltage:	3x 520/300VAC (480VAC +10% possible)
Operating frequency:	dc to 60Hz
Rated currents:	25 to 230A @ 50°C
High potential test voltage:	P → E 2750VDC for 2 sec P → P 2250VDC for 2 sec
Protection category:	IP20
Overload capability:	4x rated current at switch on, 1.5x rated current for 1 minute, once per hour
Temperature range (operation and storage):	-25°C to +100°C (25/100/21)
Flammability corresponding to:	UL 94V-2 or better
Design corresponding to:	UL 1283, CSA 22.2 No. 8 1986, IEC/EN 60939
MTBF @ 50°C/400V (Mil-HB-217F):	>300,000 hours

### Features and benefits

- High-performance filter for mainly industrial motor drive applications with extremely high noise levels, providing sufficient interference suppression to achieve Class B even with very long motor cables (e.g. machine tools with up to 12 axes with ~10 to 20m cables each).
- Broadband attenuation performance and exceptional saturating resistance ensure reliable interference suppression also in applications with regenerative drives (with an additional line impedance).
- FN 3120 operated on the mains input of machines or equipment contributes significantly to the reliability and immunity by offering protection against conducted interference phenomena coming from the environment.
- Solid, touch-safe terminal blocks offer sufficient contacting cross section according to the EN 60204-1 installation standard, which is very common for industrial equipment like machine tools.
- Compact dimensions and light weight design with good accessibility for automatic and hand tools guarantee a simple time and space-saving installation.

### Typical electrical schematic

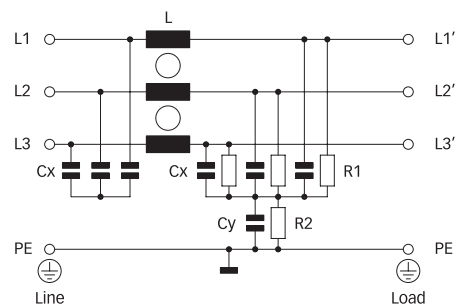

### Typical applications

Mainly industrial equipment, machinery and machine tools such as printing machines, packaging machines, extruders, wood working machines, milling and drilling machines, laser cutting machines, welding machines, robotics, conveyors, assembly lines, pumps, oil production, chemical and mining industry, etc. The filters are ideal for most motor drive applications and particularly for regenerative drives.

**Filter selection table**

Filter	Rated current @ 50°C (40°C)	Typical drive power rating*	Leakage current** @ 480VAC/50Hz	Power loss @ 25°C/50Hz	Input/Output connections	Weight
	[A]	[kW]	[mA]	[W]		[kg]
FN 3120H-25-33	25 (27)	15	97.9	17.1	-33	2.4
FN 3120H-50-53	50 (54)	30	97.9	17.5	-53	2.7
FN 3120H-80-35	80 (87)	45	97.9	25.9	-35	5.0
FN 3120H-110-35	110 (120)	55	97.9	25.4	-35	6.1
FN 3120H-150-40	150 (164)	75	97.9	40.5	-40	6.3
FN 3120H-230-40	230 (230)	132	97.9	33.5	-40	13.3

\* Calculated at rated current, 480VAC and cos phi = 0.8. The exact value depends upon the efficiency of the drive, the motor and the entire application.  
 \*\* Maximum leakage under normal operating conditions. Note: if two phases are interrupted, worst case leakage could reach 5.4 times higher levels.

**Typical filter attenuation**

Per CISPR 17; A = 50Ω/50Ω sym; B = 50Ω/50Ω asym; C = 0.1Ω/100Ω sym; D = 100Ω/0.1Ω sym

25A types

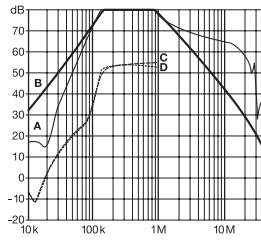

50 to 110A types

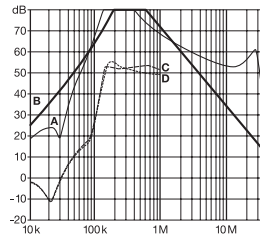

150A types

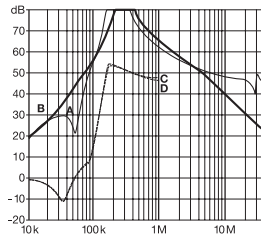

230A types

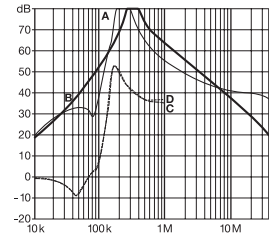

**Mechanical data**

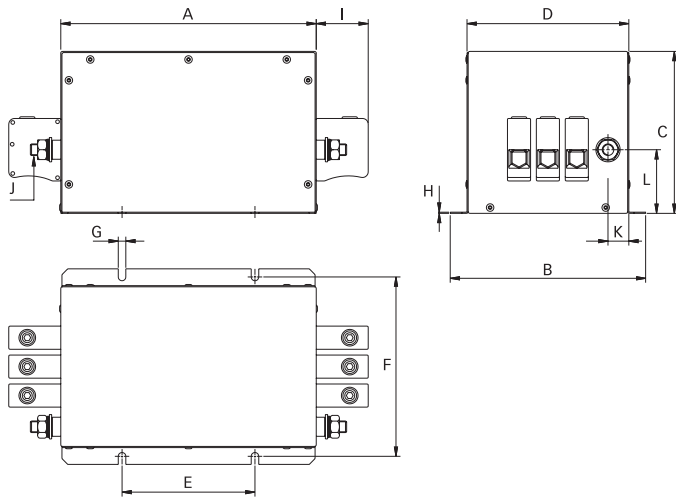

**Dimensions**

	25A	50A	80A	110A	150A	230A
<b>A</b>	214	214	221	221	221	300
<b>B</b>	159	159	169	169	169	168
<b>C</b>	64	64	140	140	140	140
<b>D</b>	129	129	140	140	140	140
<b>E</b>	115	115	115	115	115	165 (82.5/82.5)*
<b>F</b>	145	145	155	155	155	155
<b>G</b>	6.5	6.5	6.5	6.5	6.5	6.5
<b>H</b>	1	1	1	1	1	1
<b>I</b>	25	32.3	45	45	49.5	49.5
<b>J</b>	M5	M6	M10	M10	M10	M10
<b>K</b>	21.5	24.5	18	18	13	13
<b>L</b>	26	35	55	55	62	62

\* 230A filters provide 2 additional mounting slots, to do justice to the additional product weight. They are located right in the center of those mounting slots shown in the drawing above (82.5/82.5 -> 165mm).

All dimensions in mm; 1 inch = 25.4mm

Tolerances according: ISO 2768 / EN 22768

**Filter input/output connector cross sections**

	-33	-35	-40	-53
<b>Solid wire</b>	16mm <sup>2</sup>	50mm <sup>2</sup>	95mm <sup>2</sup>	25mm <sup>2</sup>
<b>Flex wire</b>	10mm <sup>2</sup>	50mm <sup>2</sup>	95mm <sup>2</sup>	16mm <sup>2</sup>
<b>AWG type wire</b>	AWG 6	AWG 1/0	AWG 4/0	AWG 4
<b>Recommended torque</b>	1.5 - 1.8Nm	7 - 8Nm	17 - 20Nm	2.0 - 2.3Nm

Please visit [www.schaffner.com](http://www.schaffner.com) to find more details on filter connectors.

## Ultra-compact EMC/RFI filter for three-phase systems and motor drives

**SCHAFFNER**  
energy efficiency and reliability



- New: solid safety connector blocks available for the whole range
- Exceptional attenuation performance from 150kHz to 30MHz
- Excellent saturation resistance up to 50m cable length
- Most compact and slim filter design in its class

### Approvals



### Technical specifications

Maximum continuous operating voltage:	3x 480/277VAC (FN 3258) 3x 520/300VAC (FN 3258H)
Operating frequency:	dc to 60Hz
Rated currents:	7 to 180A @ 50°C
High potential test voltage:	P → E 2650VDC for 2 sec P → P 2100VDC for 2 sec
Protection category:	IP20
Overload capability:	4x rated current at switch on, 1.5x rated current for 1 minute, once per hour
Temperature range (operation and storage):	-25°C to +100°C (25/100/21)
Flammability corresponding to:	UL 94V-2 or better
Design corresponding to:	UL 1283, CSA 22.2 No. 8 1986, IEC/EN 60939
MTBF @ 50°C/400V (Mil-HB-217F):	300,000 hours

### Typical electrical schematic

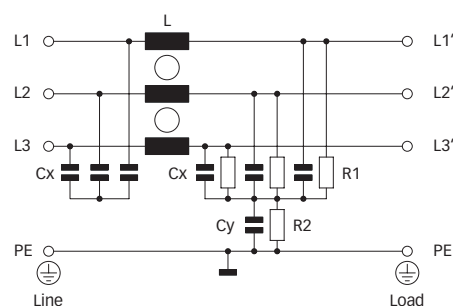



### Features and benefits

- The extremely compact and slim filter design allows a trouble-free installation even where the available mounting space is minimal.
- With new additional filter types providing safety terminal blocks, the most preferred connection style can be chosen fast and easy. This helps to stay in line with the electrical connection concept of a given application.
- FN 3258 filters ensure compliance with Class A limits according to EN 55011 up to 50m cable length and beyond. Further they can contribute significantly to meet conducted emission limits according to Class B.
- Filter operation on the mains input side of consumers increases their reliability and conducted immunity significant.
- Chokes with exceptional saturation resistance and excellent thermal behavior are a vital part of FN 3258 design. Thus, all filters retain the expected filter performance even in very noisy applications and under full load conditions.

### Typical applications

- Three-phase variable speed motor drives, servo drives, inverters and converters
- Applications comprising energy conversion devices like machines or process automation equipment
- HVAC equipment, elevators, power supplies, UPS and further three-phase applications

Filter selection table

Filter*	Rated current @ 50°C (40°C)	Typical drive power rating**	Leakage current*** @ 400VAC/50Hz	Power loss @ 25°C/50Hz	Input/Output connections		Weight
	[A]	[kW]	[mA]	[W]			[kg]
FN 3258-7-..	7 (7.7)	4	33.0	3.8	-45	-44	0.5
FN 3258-16-..	16 (17.5)	7.5	33.0	6.1	-45	-44	0.8
FN 3258-30-..	30 (32.9)	15	33.0	11.8	-47	-33	1.2
FN 3258-42-..	42 (46.0)	22	33.0	15.7	-47	-33	1.4
FN 3258-55-..	55 (60.2)	30	33.0	25.9	-52	-34	2.0
FN 3258-75-..	75 (82.2)	37	33.0	32.2	-52	-34	2.7
FN 3258-100-35	100 (109.5)	55	33.0	34.5		-35	4.3
FN 3258-130-35	130 (142.4)	75	33.0	43.1		-35	4.5
FN 3258-180-40	180 (197.1)	90	33.0	58.3		-40	6.0

FN 3258H-7-..	7 (7.7)	4	33.0	3.8	-45	-44	0.5
FN 3258H-16-..	16 (17.5)	7.5	33.0	6.1	-45	-44	0.8
FN 3258H-30-..	30 (32.9)	18.5	33.0	11.8	-47	-33	1.2
FN 3258H-42-..	42 (46.0)	22	33.0	15.7	-47	-33	1.4
FN 3258H-55-..	55 (60.2)	37	33.0	25.9	-52	-34	2.0
FN 3258H-75-..	75 (82.2)	45	33.0	32.2	-52	-34	2.7
FN 3258H-100-35	100 (109.5)	55	33.0	34.5		-35	4.3
FN 3258H-130-35	130 (142.4)	75	33.0	43.1		-35	4.5
FN 3258H-180-40	180 (197.1)	110	33.0	58.3		-40	6.0

\* To compile a complete part number, please replace the .. with the required I/O connection style.

\*\* Calculated at rated current, 440VAC (FN 3258)/480VAC (FN 3258H) and cos phi = 0.8. The exact value depends upon the efficiency of the drive, the motor and the entire application.

\*\*\* Maximum leakage under normal operating conditions. Note: if two phases are interrupted, worst case leakage could reach 5.4 times higher levels.

Typical filter attenuation

Per CISPR 17; A = 50Ω/50Ω sym; B = 50Ω/50Ω asym; C = 0.1Ω/100Ω sym; D = 100Ω/0.1Ω sym

7 to 42A types

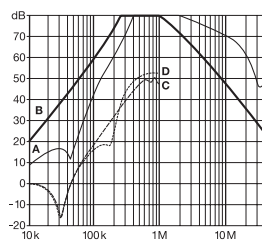

55 to 100A types

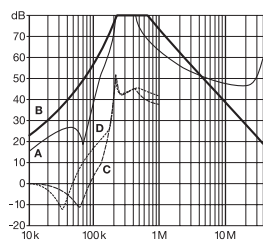

130 and 180A types

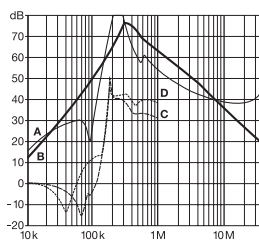

**Mechanical data**

Filters with strip terminals (7 to 75A types)

Filters with safety connector blocks (7 to 180A types)

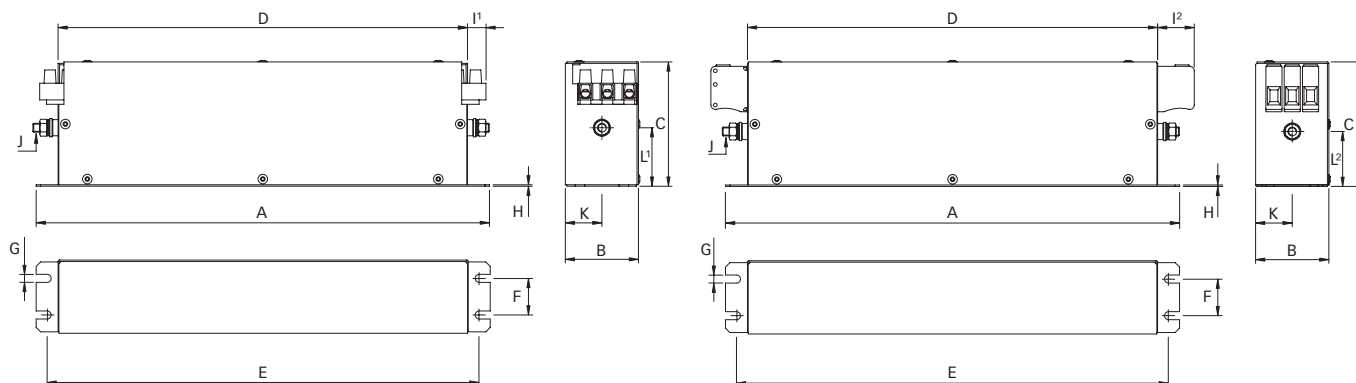

Note: in favour of a better readability, connectors and earth studs are not shown in the horizontal projection.

**Dimensions**

	7A	16A	30A	42A	55A	75A	100A	130A	180A
A	190	250	270	310	250	270	270	270	380
B	40	45	50	50	85	80	90	90	120
C	70	70	85	85	90	135	150	150	170
D	160	220	240	280	220	240	240	240	350
E	180	235	255	295	235	255	255	255	365
F	20	25	30	30	60	60	65	65	102
G	4.5	5.4	5.4	5.4	5.4	6.5	6.5	6.5	6.5
H	1	1	1	1	1	1.5	1.5	1.5	1.5
I1	10.6	10.6	12.6	12.6	19	19			
I2	22	22	25	25	39	39	45	45	49.5
J	M5	M5	M5	M6	M6	M6	M10	M10	M10
K	20	22.5	25	25	42.5	40	45	45	60
L1	31	31	40	40	45	60			
L2	29.5	29.5	39.5	37.5	26.5	70.5	64	64	47

All dimensions in mm; 1 inch = 25.4mm  
Tolerances according: ISO 2768 / EN 22768

**Filter input/output connector cross sections**

	-33	-34	-35	-40	-44	-45	-47	-52
<b>Solid wire</b>	16mm <sup>2</sup>	35mm <sup>2</sup>	50mm <sup>2</sup>	95mm <sup>2</sup>	10mm <sup>2</sup>	6mm <sup>2</sup>	16mm <sup>2</sup>	25mm <sup>2</sup>
<b>Flex wire</b>	10mm <sup>2</sup>	25mm <sup>2</sup>	50mm <sup>2</sup>	95mm <sup>2</sup>	6mm <sup>2</sup>	4mm <sup>2</sup>	10mm <sup>2</sup>	16mm <sup>2</sup>
<b>AWG type wire</b>	AWG 6	AWG 2	AWG 1/0	AWG 4/0	AWG 8	AWG 12	AWG 8	AWG 4
<b>Recommended torque</b>	1.5 - 1.8Nm	4.0 - 4.5Nm	7 - 8Nm	17 - 20Nm	1.5 - 1.8Nm	0.7 - 0.8Nm	1.9 - 2.2Nm	1.9 - 2.2Nm

Please visit [www.schaffner.com](http://www.schaffner.com) to find more details on filter connectors.

## Compact three-phase EMC/RFI filter for industrial motor drive applications

# SCHAFFNER

energy efficiency and reliability



- Very compact and light weight design requiring minimum space
- Easy, time-saving installation and contacting
- Protective covers as optional accessory available
- Attenuation performance according to EN 61800-3/A11

### Approvals



### Technical specifications

Maximum continuous operating voltage:	3x 520/300VAC (480VAC +10% possible)
Operating frequency:	dc to 60Hz
Rated currents:	10 to 1000A @ 50°C
High potential test voltage:	P → E 2750VDC for 2 sec P → P 2250VDC for 2 sec
Protection category:	IP20 (10 to 100A) IP00 (150 to 1000A)
Overload capability:	4x rated current at switch on, 1.5x rated current for 1 minute, once per hour
Temperature range (operation and storage):	-25°C to +100°C (25/100/21)
Flammability corresponding to:	UL 94V-2 or better
Design corresponding to:	UL 1283, CSA 22.2 No. 8 1986, IEC/EN 60939
MTBF @ 50°C/400V (Mil-HB-217F):	>320,000 hours

### Typical electrical schematic

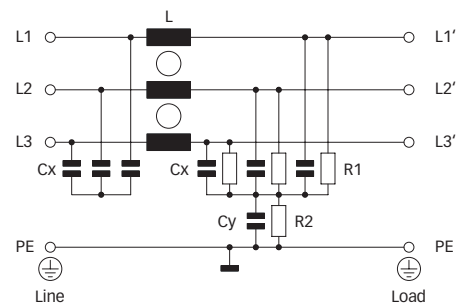

### Features and benefits

- An extremely compact and light weight filter design requiring minimum mounting space in installations and cabinets.
- Simple and time-saving installation with good accessibility for automatic and hand tools.
- Solid, touch-safe terminal blocks, for all filters from 10 to 100A, offering sufficient contacting cross section according to the EN 60204-1 installation standard.
- Optionally available transparent protective covers for all filters with busbars from 150 to 1000A, to protect the installer, operator or inspector from undeliberate touching of live conductors. They can easily be retro-fitted even if the filter is already installed and connected.
- These EMC filters provide the attenuation performance needed to fulfill EN 61800-3/A11.
- Guaranteed filter performance under full-load operating conditions.
- 15 different filter models allow the specific choice and deployment for most industrial applications.

### Typical applications

- Variable speed electrical power drive systems/motor drives for mainly industrial purpose
- Various industrial applications comprising frequency inverters, motor drives and servo drives

**Filter selection table**

Filter	Rated current @ 50°C (40°C)	Typical drive power rating*	Leakage current** @ 480VAC/50Hz	Power loss @ 25°C/50Hz	Input/Output connections 	Weight [kg]	Protective covers***
	[A]	[kW]	[mA]	[W]			Order code
FN 3270H-10-44	10 (11)	5.5	26.4	2.4	-44	0.4	
FN 3270H-20-44	20 (22)	11	26.4	4.1	-44	0.5	
FN 3270H-35-33	35 (38)	22	29.4	6.8	-33	0.7	
FN 3270H-50-34	50 (55)	30	29.4	12.8	-34	1.2	
FN 3270H-65-34	65 (71)	37	29.4	13.5	-34	1.3	
FN 3270H-80-35	80 (88)	45	29.4	13.5	-35	2.2	
FN 3270H-100-35	100 (110)	55	29.4	17.1	-35	2.6	
FN 3270H-150-99	150 (164)	75	59.5	7.5	-99	6.1	1151-047
FN 3270H-200-99	200 (219)	110	59.5	13.2	-99	6.1	1151-047
FN 3270H-250-99	250 (274)	132	59.5	20.6	-99	6.1	1151-047
FN 3270H-320-99	320 (350)	160	59.5	12.2	-99	7.2	1151-047
FN 3270H-400-99	400 (438)	220	59.5	19.2	-99	7.2	1151-047
FN 3270H-600-99	600 (657)	315	59.5	35.6	-99	7.7	1151-047
FN 3270H-800-99	800 (876)	400	59.5	51.8	-99	15.8	1151-049
FN 3270H-1000-99	1000 (1095)	560	59.5	81.0	-99	15.8	1151-049

\* Calculated at rated current, 480VAC and cos phi = 0.8. The exact value depends upon the efficiency of the drive, the motor and the entire application.

\*\* Maximum leakage under normal operating conditions. Note: if two phases are interrupted, worst case leakage could reach 5.2 times higher levels.

\*\*\* Please contact your local Schaffner partner to order the optional protective covers with the order code in the table above.

**Typical filter attenuation**

Per CISPR 17; A = 50Ω/50Ω sym; B = 50Ω/50Ω asym; C = 0.1Ω/100Ω sym; D = 100Ω/0.1Ω sym

10 and 20A types

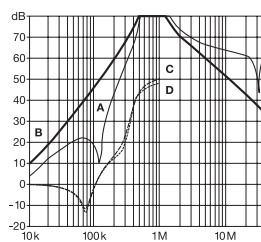

35 to 65A types

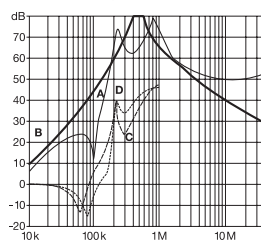

80 and 100A types

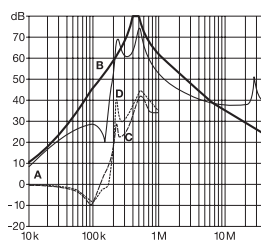

150 to 1000A types

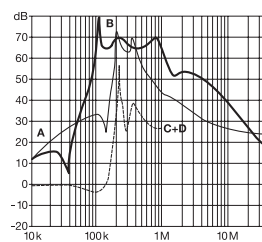

**Mechanical data**

10 to 100A types

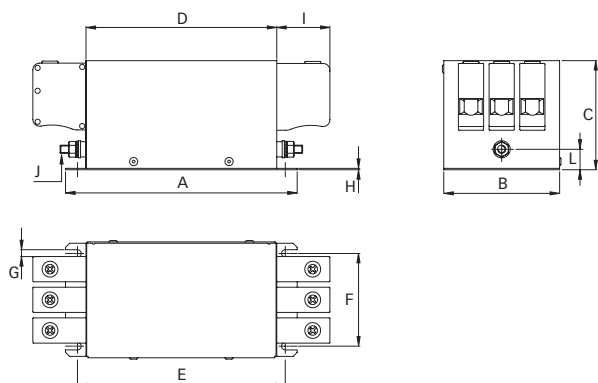

150 to 1000A types

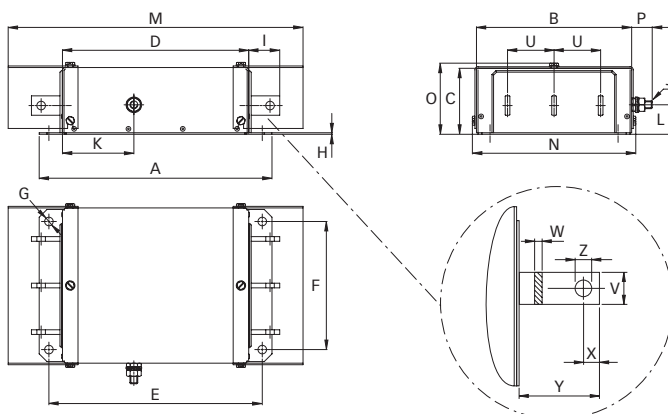

**Dimensions**

	10A	20A	35A	50A	65A	80A	100A	150A	200A	250A	320A	400A	600A	800A	1000A
A	150	150	160	170	170	200	230	300	300	300	300	300	300	370	370
B	58	58	70	85	85	95	95	200	200	200	200	200	200	190	190
C	58	58	68	80	80	90	90	86	86	86	86	86	86	125	125
D	120	120	130	140	140	170	200	240	240	240	240	240	240	310	310
E	132.5	132.5	142.5	152.5	152.5	182.5	212.5	275	275	275	275	275	275	345	345
F	42	42	50	65	65	75	75	165	165	165	165	165	165	155	155
G	4.5	4.5	5.5	5.5	5.5	5.5	5.5	Ø11	Ø11	Ø11	Ø11	Ø11	Ø11	Ø11	Ø11
H	1	1	1	1	1	1.5	1.5	2	2	2	2	2	2	3	3
I	21.9	21.9	25	39	39	45	45	40	40	40	40	40	40	50	50
J	M4	M4	M5	M6	M6	M8	M8	M10	M10	M10	M10	M10	M10	M12	M12
K								92	92	92	92	92	92	138	138
L	20.5	20.5	20	15	15	16	16	37	37	37	37	37	37	67	67
M								380	380	380	380	380	380	610	610
N								211	211	211	211	211	211	201	201
O								93	93	93	93	93	93	132	132
P								26.5	26.5	26.5	26.5	26.5	26.5	29	29
U								60	60	60	60	60	60	60	60
V								20	20	20	25	25	25	40	40
W								3	3	3	6	6	8	8	8
X								10	10	10	12.5	12.5	12.5	20	20
Y								37	37	37	37	37	37	47	47
Z								Ø9	Ø9	Ø9	Ø11	Ø11	Ø11	Ø13.5	Ø13.5

All dimensions in mm; 1 inch = 25.4mm  
Tolerances according: ISO 2768 / EN 22768

**Filter input/output connector cross sections**

	-33	-34	-35	-44
<b>Solid wire</b>	16mm <sup>2</sup>	35mm <sup>2</sup>	50mm <sup>2</sup>	10mm <sup>2</sup>
<b>Flex wire</b>	10mm <sup>2</sup>	25mm <sup>2</sup>	50mm <sup>2</sup>	6mm <sup>2</sup>
<b>AWG type wire</b>	AWG 6	AWG 2	AWG 1/0	AWG 8
<b>Recommended torque</b>	1.5 - 1.8Nm	4.0 - 4.5Nm	7 - 8Nm	1.5 - 1.8Nm

Please visit [www.schaffner.com](http://www.schaffner.com) to find more details on filter connectors.

## High-current three-phase EMC/RFI filter

# SCHAFFNER

energy efficiency and reliability



- Off-the-shelf high-power filter for rated currents up to 2500A
- HV versions designed for 690VAC IT power networks
- Busbars for convenient and universal electrical connection
- Protective plastic covers optionally available for unsurpassed safety

Approvals (filters up to 1000A)



### Technical specifications

Maximum continuous operating voltage:	3x 520/300VAC (FN 3359) 3x 690/400VAC (FN 3359HV)
Operating frequency:	dc to 60Hz
Rated currents:	150 to 2500A @ 50°C
High potential test voltage:	P → E 2700VDC for 2 sec (FN 3359) P → P 2150VDC for 2 sec (FN 3359) P → E 3100VDC for 2 sec (FN 3359HV) P → P 3000VDC for 2 sec (FN 3359HV)
Protection category:	IP00
Overload capability:	4x rated current at switch on, 1.5x rated current for 1 minute, once per hour
Temperature range (operation and storage):	-25°C to +100°C (25/100/21)
Flammability corresponding to:	UL 94V-2 or better
Design corresponding to:	UL 1283, CSA 22.2 No. 8 1986, IEC/EN 60939
MTBF @ 45°C/480V (Mil-HB-217F):	130,000 hours

### Typical electrical schematic

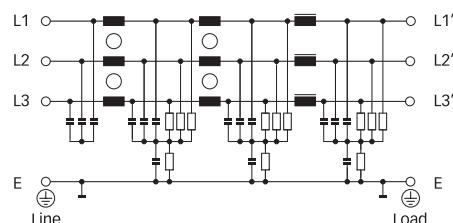

Note: HV versions without discharge resistor to ground.



### Features and benefits

- High-power filter for Class A compliance. With approval measurement also Class B compliance possible for some applications.
- Extremely compact high-current filter solution with minimum space requirement.
- FN 3359HV versions for 690VAC are also designed for use in IT power networks.
- All filters 320A and above are suitable for regenerative motor drive system (with a suitable line reactor).
- Optionally available transparent protective covers for all filters up to 1000A, to protect the installer, operator or inspector from undeliberate touching of live conductors. They can easily be retrofitted even if the filter is already installed and connected.
- FN 3359 also improves conducted immunity of installations.

### Typical applications

- High-power motor drives, inverters and converters
- Industrial three-phase systems
- Entire factories, plants and installations
- Large UPS
- Machinery
- Mining equipment
- Renewable power generation

**Filter selection table**

Filter	Rated current @ 50°C (40°C)	Typical drive power rating*	Leakage current** @ 480VAC/50Hz	Power loss @ 25°C/50Hz	Input/Output connections	Weight	Protective covers***
	[A]	[kW]	[mA]	[W]	 	[kg]	Order code
FN 3359-150-28	150 (164)	75	<6	24	-28	6.5	1151-050
FN 3359-180-28	180 (197)	90	<6	34	-28	6.5	1151-050
FN 3359-250-28	250 (250)	132	<6	49	-28	7.0	1151-051
FN 3359-320-99	320 (350)	160	<6	19	-99	10.5	1151-052
FN 3359-400-99	400 (438)	220	<6	29	-99	10.5	1151-052
FN 3359-600-99	600 (657)	315	<6	44	-99	11.0	1151-053
FN 3359-800-99	800 (876)	400	<6	39	-99	18.0	1151-054
FN 3359-1000-99	1000 (1095)	560	<6	60	-99	18.0	1151-054
FN 3359-1600-99	1600 (1600)	900	<6	131	-99	27.0	
FN 3359-2500-99	2500 (2500)	1320	<6	300	-99	55.0	
FN 3359HV-150-28	150 (164)	110	<6	24	-28	6.5	1151-050
FN 3359HV-180-28	180 (197)	132	<6	34	-28	6.5	1151-050
FN 3359HV-250-28	250 (250)	200	<6	49	-28	7.0	1151-051
FN 3359HV-320-99	320 (350)	250	<6	19	-99	10.5	1151-052
FN 3359HV-400-99	400 (438)	315	<6	29	-99	10.5	1151-052
FN 3359HV-600-99	600 (657)	500	<6	44	-99	11.0	1151-053
FN 3359HV-800-99	800 (876)	630	<6	39	-99	18.0	1151-054
FN 3359HV-1000-99	1000 (1095)	710	<6	60	-99	18.0	1151-054
FN 3359HV-1600-99	1600 (1600)	1320	<6	131	-99	27.0	
FN 3359HV-2500-99	2500 (2500)	2000	<6	300	-99	55.0	

\* Calculated at rated current, 480VAC (FN 3359) / 690VAC (FN 3359HV) and cos phi = 0.8. The exact value depends upon the efficiency of the drive, the motor and the entire application.

\*\* Maximum leakage under normal operating conditions. Note: if two phases are interrupted, worst case leakage could be much higher than the value shown.

\*\*\* Please contact your local Schaffner partner to order the optional protective covers with the order code in the table above

**Typical filter attenuation**

Per CISPR 17; A = 50Ω/50Ω sym; B = 50Ω/50Ω asym; C = 0.1Ω/100Ω sym; D = 100Ω/0.1Ω sym

150 to 180A types

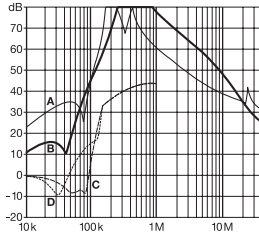

250 to 600A types

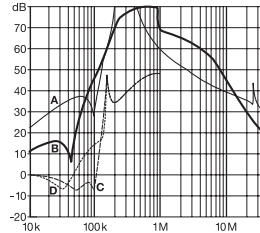

800 and 1000A types

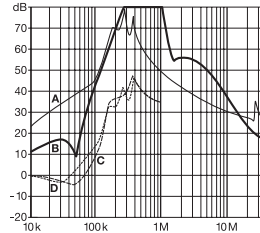

1600 and 2500A types

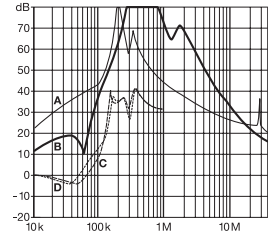

**Mechanical data**

150 to 250A types

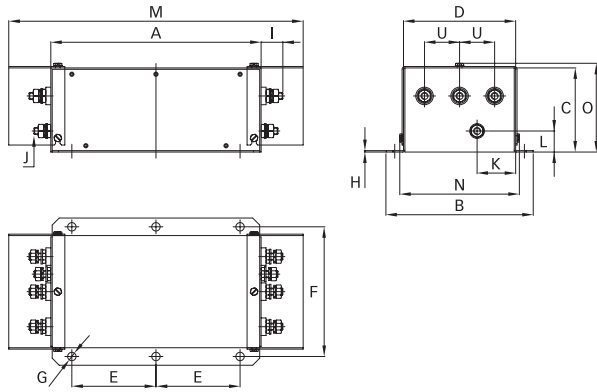

320 to 2500A types

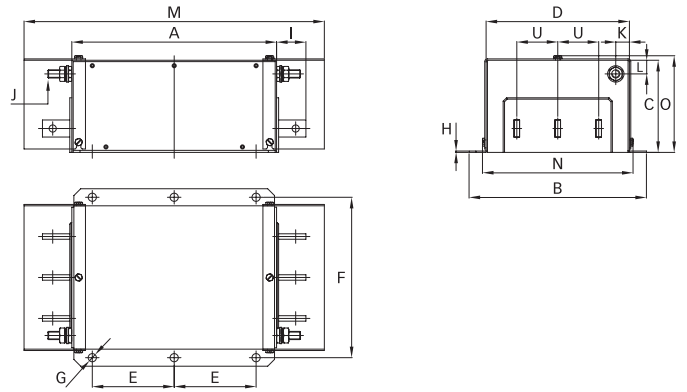

**Busbar connections**

320 to 1000A types

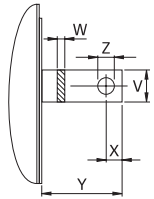

1600A types

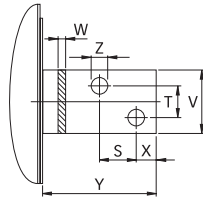

2500A types

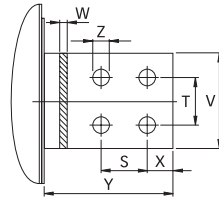

**Dimensions**

	150A	180A	250A	320A	400A	600A	800A	1000A	1600A	2500A
A	300	300	300	300	300	300	350	350	400	600
B	210	210	230	260	260	260	280	280	300	370
C	120	120	125	115	115	135	170	170	160	200
D	160	160	180	210	210	210	230	230	250	300
E	120	120	120	120	120	120	145	145	170	250
F	185	185	205	235	235	235	255	255	275	330
G	Ø12	Ø12	Ø12	Ø12	Ø12	Ø12	Ø12	Ø12	Ø12	Ø14
H	2	2	2	2	2	2	3	3	3	3
I	32	32	32	43	43	43	53	53	93	98
J	M10	M10	M10	M12	M12	M12	M12	M12	M12	M16
K	55	55	62.5	20	20	20	25	25	25	25
L	30	30	35	20	20	20	25	25	25	25
M	420	420	420	440	440	440	510	510		
N	171	171	191	221	221	221	241	241		
O	127	127	132	122	122	142	177	177		
S									26	35
T									26	35
U	50	50	55	60	60	60	60	60	60	100
V				25	25	25	40	40	60	70
W				6	6	8	8	8	10	15
X				15	15	15	20	20	17	20
Y				40	40	40	50	50	90	95
Z				Ø10.5	Ø10.5	Ø10.5	Ø14	Ø14	Ø14	Ø14

All dimensions in mm; 1 inch = 25.4mm  
Tolerances according: ISO 2768 / EN 22768